

# GADNIC

MANUAL DE USUARIO

LÁMPARA DE MESA CON LUPA



**LUPV001**

## INDICE

|                |    |
|----------------|----|
| ESPAÑOL.....   | 03 |
| ENGLISH.....   | 06 |
| PORTUGUÊS..... | 09 |

# INSTRUCCIONES DE USO

## LAMPARA DE MESA CON LUPA LUPV0011



LEA ATENTAMENTE LAS INSTRUCCIONES ANTES DE SU USO. RESERVE EL MANUAL  
PARA FUTURAS CONSULTAS

Brazo de la lámpara



Pinza de la lámpara

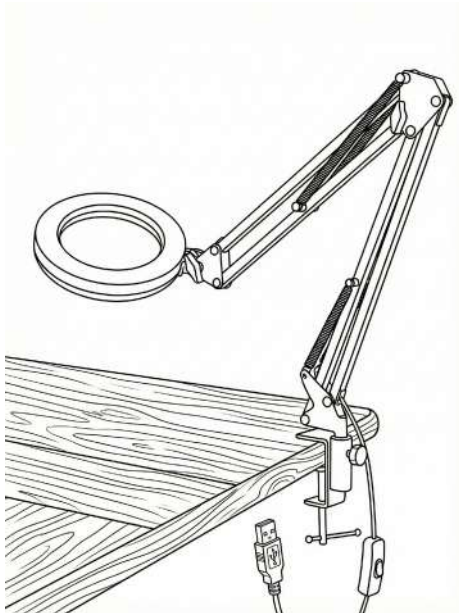

Tipo de pinza: inserte el brazo de la lámpara directamente en la pinza.

La pinza se fija a la mesa

Chasis



# Notas

- Conexión: Interfaz USB.
- Nota importante: No incluye el adaptador de pared. Requisito: Se recomienda usar un adaptador de carga de 5V/2A o 5V/3A.  
luminación
- Fuente de luz: 72 diodos LED. Potencia: 12 Watts (12W).
- Tono de luz (Temperatura): entre 3000K (cálido) y 6500K (frío).
- Lupa de tamaño 11 cm de diámetro y aumento: 10X.
- Garantía: 1 año. Las reparaciones por defectos son gratuitas dentro de este periodo.
- Limpieza: Limpiar diariamente con un paño suave.
- Seguridad: No abrir el dispositivo. Para evitar el riesgo de descargas eléctricas, el desmontaje solo debe ser realizado por profesionales.

# INSTRUCTIONS FOR USE

## MAGNIFYING DESK LAMP LUPV0011



PLEASE READ THE INSTRUCTIONS CAREFULLY BEFORE USE. KEEP THE MANUAL FOR FUTURE REFERENCE

Lamp arm



Lamp clip

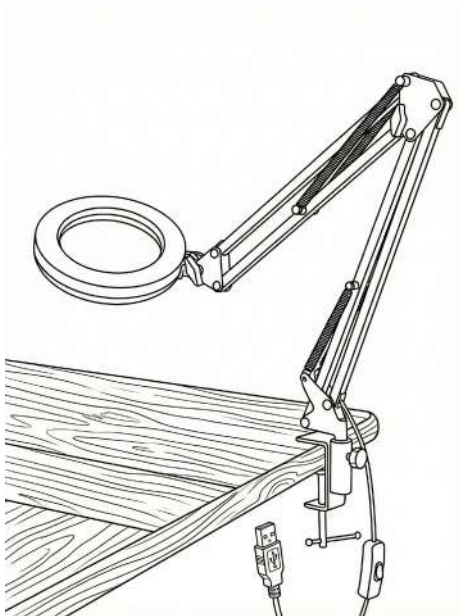

Clip type: insert the lamp arm directly into the clip.

The clip is fixed to the table

Chassis



# Notes

- Connection: USB Interface.
- Important note: Wall adapter is not included. Requirement: It is recommended to use a 5V/2A or 5V/3A charging adapter. Lighting.
- Light source: 72 LED diodes. Power: 12 Watts (12W).
- Light tone (Temperature): Between 3000K (warm) and 6500K (cool)
- Magnifying glass size: 11 cm in diameter and magnification: 10X.
- Warranty: 1 year. Repairs for defects are free within this period.
- Cleaning: Clean daily with a soft cloth.
- Safety: Do not open the device. To avoid the risk of electric shock, disassembly should only be performed by professionals.

# INSTRUÇÕES DE USO

## LUMINÁRIA DE MESA COM LUPA LUPV0011



LEIA ATENTAMENTE AS INSTRUÇÕES ANTES DE USAR. GUARDE O MANUAL PARA FUTURAS CONSULTAS

**Braço da lâmpada**



**Grampo da lâmpada**

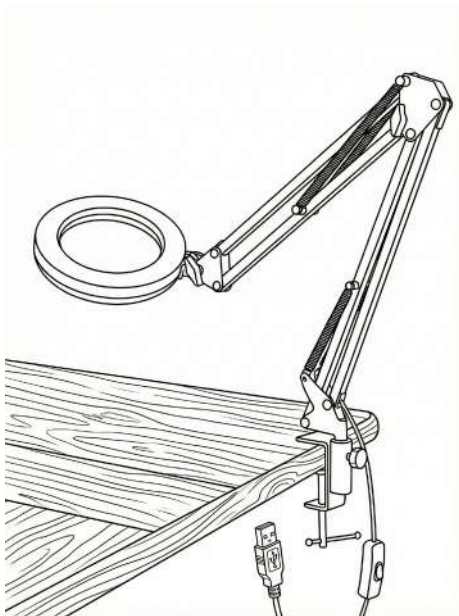

Tipo de grampo: insira o braço da lâmpada diretamente no grampo.

O grampo fixa-se à mesa

**Chassi**



# Notas

- Conexão: Interface USB.
- Nota importante: Não inclui o adaptador de parede. Requisito: Recomenda-se usar um adaptador de carga de 5V/2A ou 5V/3A. Iluminação.
- Fonte de luz: 72 diodos LED. Potência: 12 Watts (12W).
- Tom de luz (Temperatura): Entre 3000K (quente) e 6500K (frio).
- Tamanho da lupa: 11 cm de diâmetro e aumento: 10X.
- Garantia: 1 ano. Os reparos por defeitos são gratuitos dentro deste período.
- Limpeza: Limpar diariamente com um pano macio.
- Segurança: Não abrir o dispositivo. Para evitar o risco de choques elétricos, a desmontagem deve ser realizada apenas por profissionais.

## ¿Necesitás ayuda?

Ingresa a nuestro soporte técnico escaneando el QR o escribinos por nuestros canales oficiales.



**11 6260 1114 (sólo texto)**



**serviciotecnico@bidcom.com.ar**



**www.bidcomservice.com.ar**

**Bidcom**  
SERVICE

