

# GADNIC

## MANUAL DE USUARIO BARRA DE DOMINADAS



**FITNES701**

LEA ATENTAMENTE LAS INSTRUCCIONES ANTES DE SU USO. RESERVE EL MANUAL  
PARA FUTURAS CONSULTAS

## INDICE

ESPAÑOL.....	03
PORTUGUÊS.....	08
ENGLISH.....	13

# INSTRUCCIONES DE USO

## BARRA PULL UP FITNES701

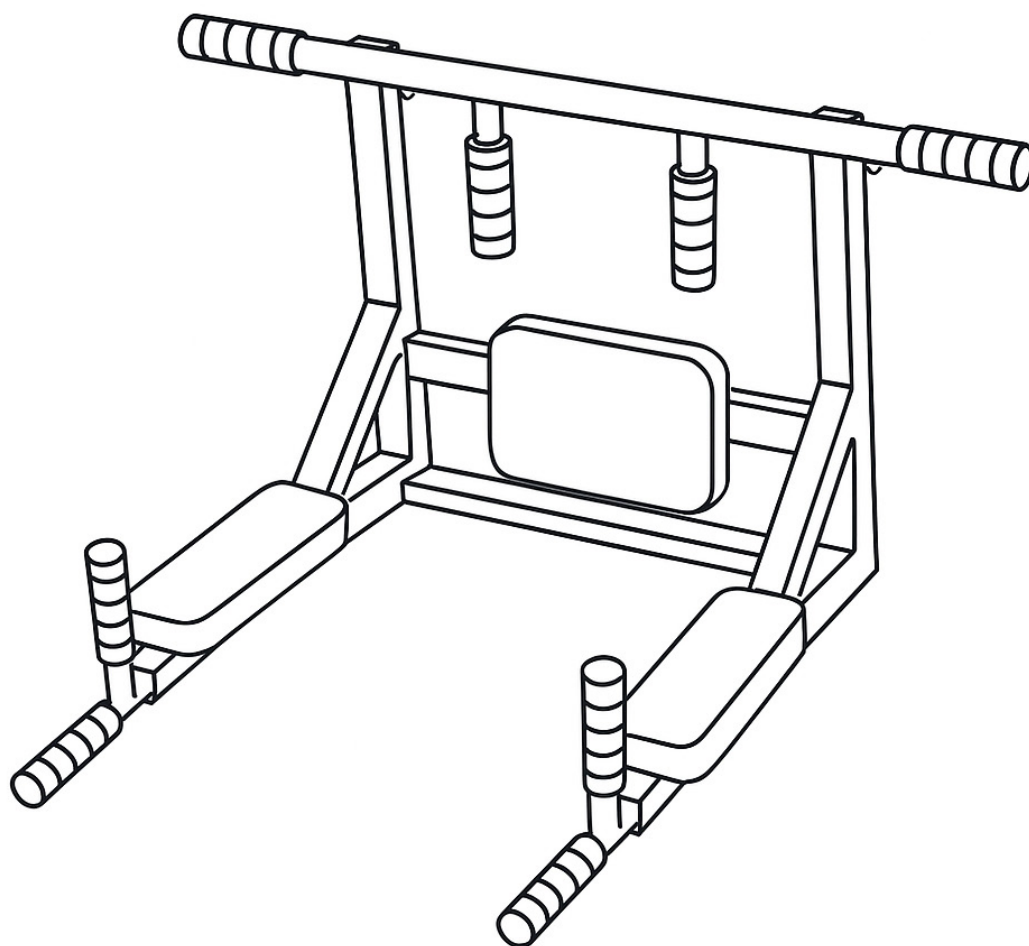

LEA ATENTAMENTE LAS INSTRUCCIONES ANTES DE SU USO. RESERVE EL MANUAL  
PARA FUTURAS CONSULTAS



Reposabrazos largo  
(A)

Respaldo cuadrado  
(B)



Tubo de conexión  
multifuncional  
(C)



Tubo de conexión  
principal  
(D)



Tubo de conexión  
multifuncional y  
marco principal  
(E)



Gancho de pared

# Instalación del respaldo y reposabrazos

Usar tornillos del grupo B

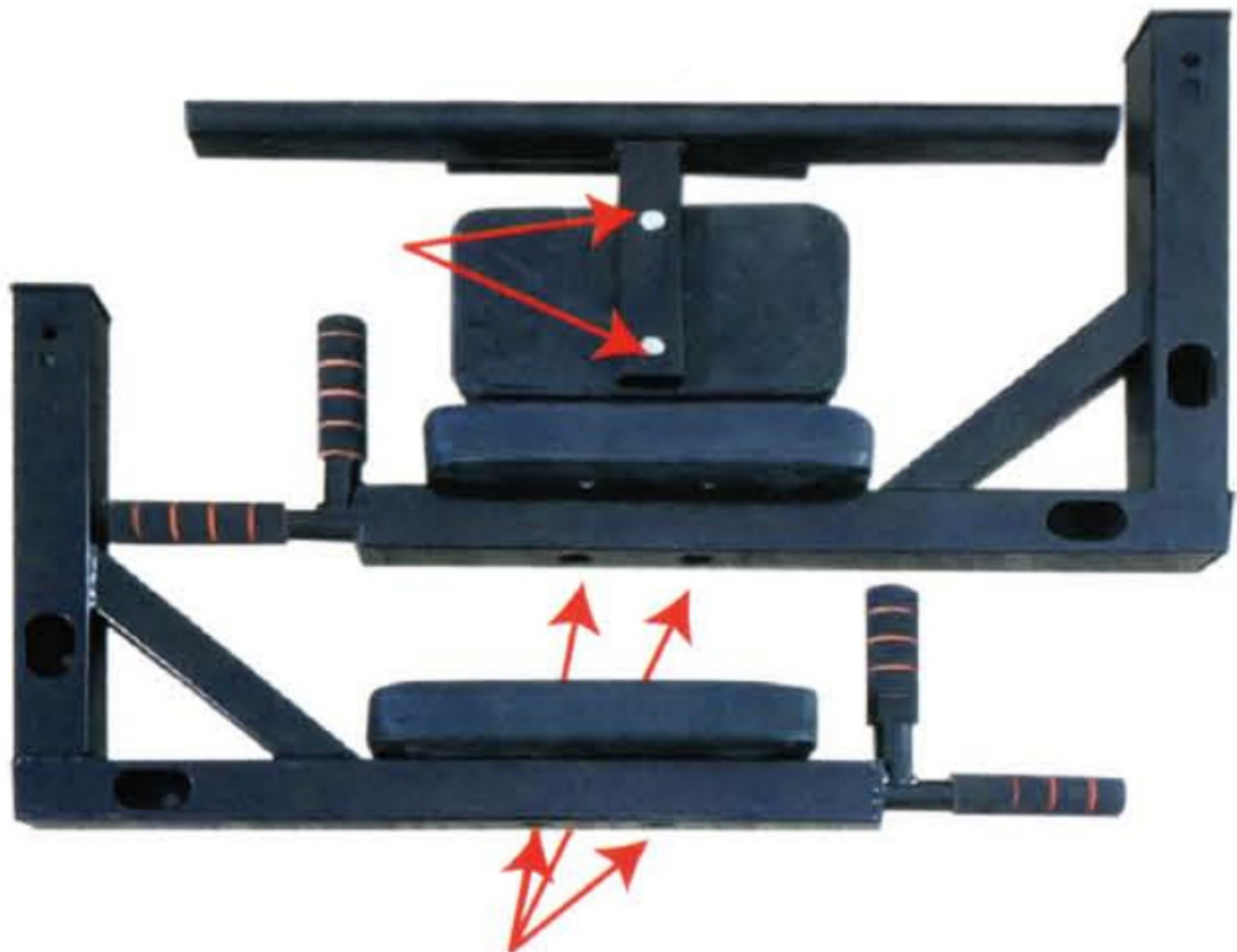

Usar tornillos del grupo A

# Instalación del tubo de conexión multifunción

Usar tornillos del grupo C



Primero, junte los tubos de conexión multifuncionales izquierdo y derecho. Luego, coloque los tornillos para alinearlos en sus agujeros y ajústelos **sin apretar del todo**.

Si los aprieta por completo ahora, esto dificultará que los siguientes pasos de la instalación se puedan hacer correctamente.

## Montar el soporte principal



Inserte en el agujero correspondiente, como indican las flechas en la figura

## Fijar el soporte principal



Para atornillar, se recomienda primero colocar sin apretar todos los tornillos en sus agujeros. Una vez que todos los tornillos estén puestos, puede proceder a apretarlos firmemente. Haga esto para asegurarse de que el marco principal quede bien instalado.



Finalmente, refuerce y apriete todos los tornillos.

¡El ensamblaje del producto está completo!

# INSTRUÇÕES DE USO

## BARRA PULL UP FITNES701

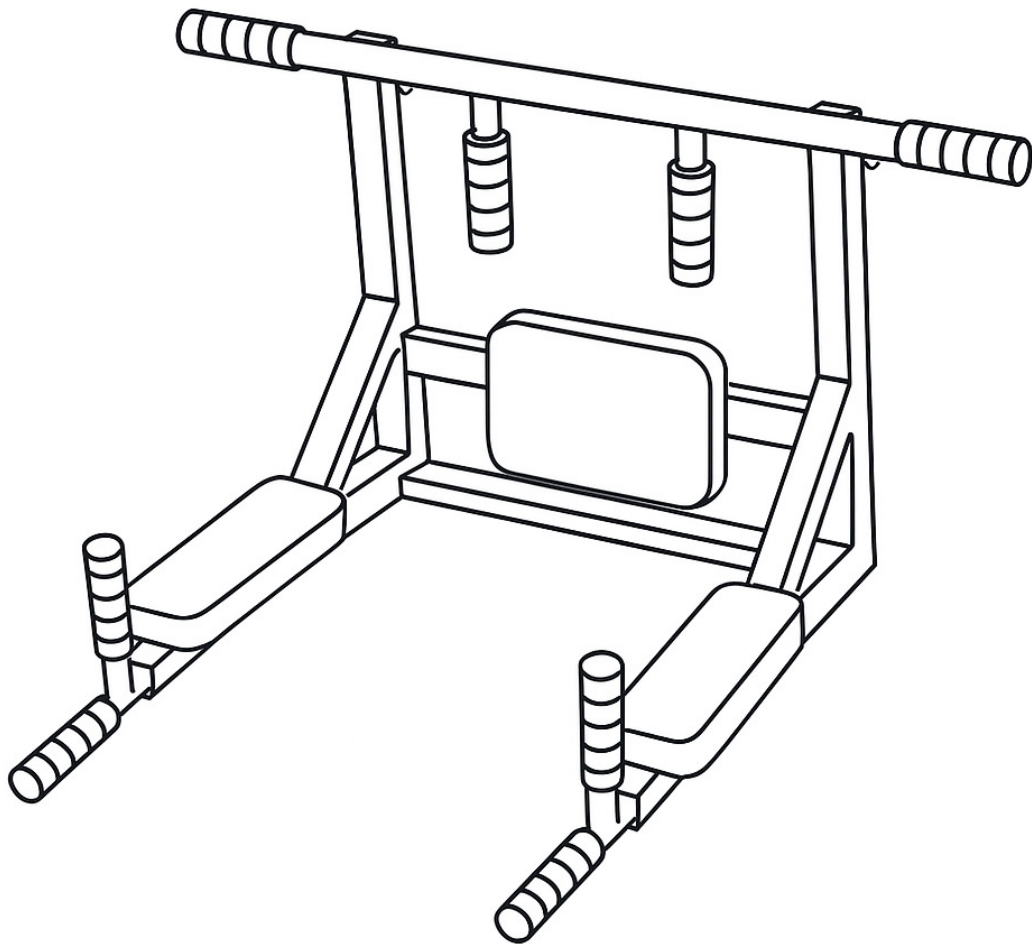

LEIA ATENTAMENTE AS INSTRUÇÕES ANTES DE USÁ-LAS. RESERVE O MANUAL  
PARA REFERÊNCIA FUTURA



Apoio de braço longo  
(A)

Encosto quadrado  
(B)



Tubo de conexão  
multifuncional  
(C)



Tubo de conexão  
principal  
(D)



Tubo de conexão  
multifuncional e es-  
trutura principal  
(E)



Gancho de parede

# Instalação do encosto e apoio de braço

Usar parafusos do grupo B

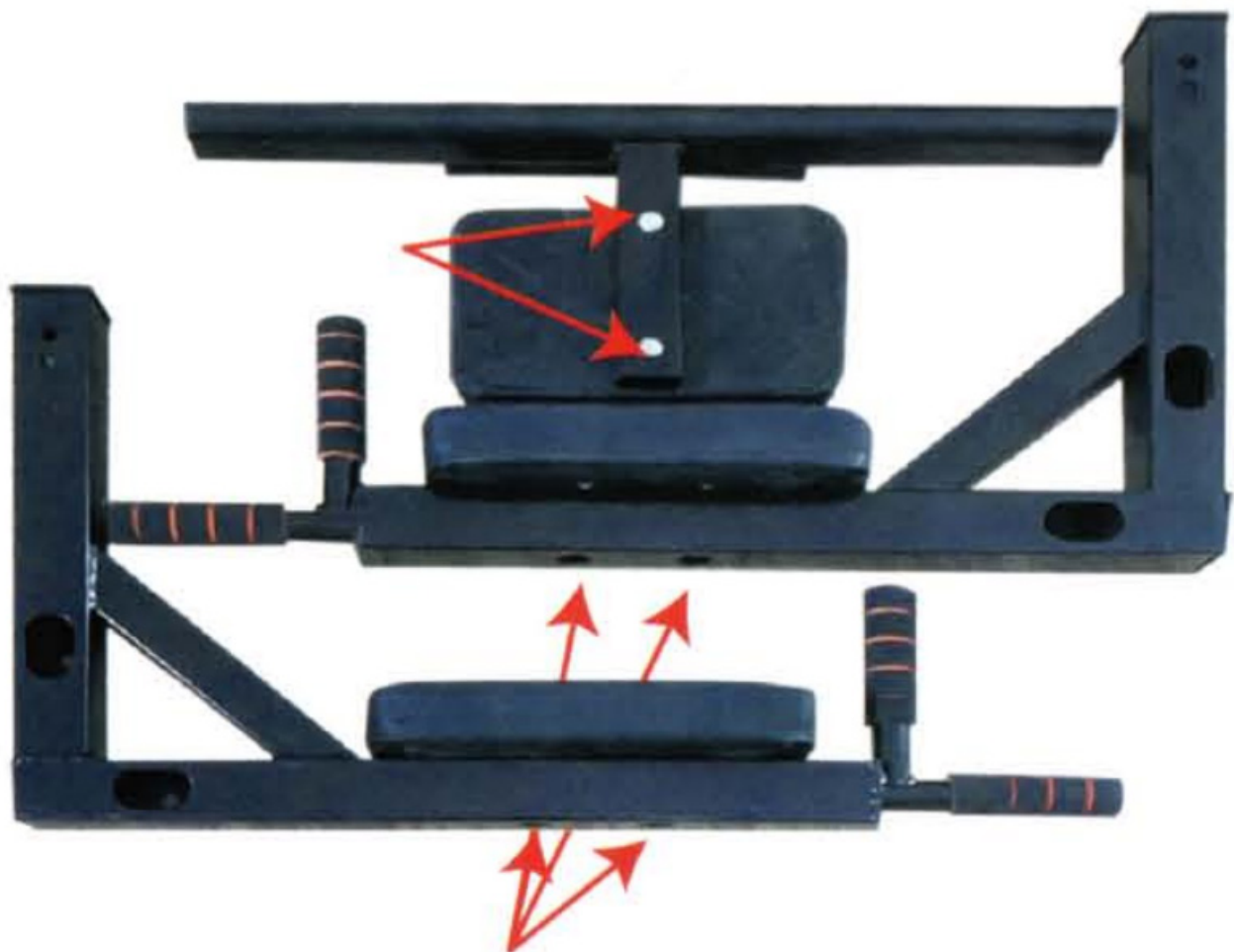

Usar parafusos do grupo A

# Instalação do tubo de conexão multifuncional

Usar parafusos do grupo C



Primeiro, junte os tubos de conexão multifuncionais esquerdo e direito.

Em seguida, coloque os parafusos para alinhá-los em seus furos e ajuste-os **sem apertar totalmente**

Se você os apertar completamente agora, isso dificultará a correta execução dos próximos passos da instalação.

## Montar o suporte principal

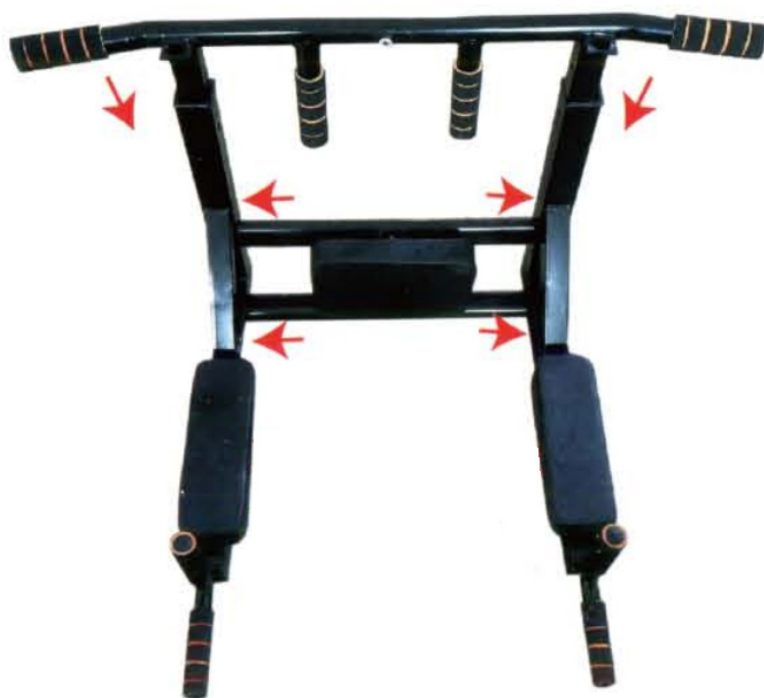

Insira no furo correspondente, conforme indicado pelas setas na figura.

## Fixar o suporte principal



Para parafusar, recomenda-se primeiro colocar todos os parafusos em seus furos sem apertá-los. Uma vez que todos os parafusos estejam no lugar, você pode proceder para apertá-los firmemente. Faça isso para garantir que a estrutura principal esteja bem instalada.



Finalmente, reforce e aperte todos os parafusos.

A montagem do produto está completa!

# INSTRUCTIONS FOR USE

## PULL UP BAR FITNES701

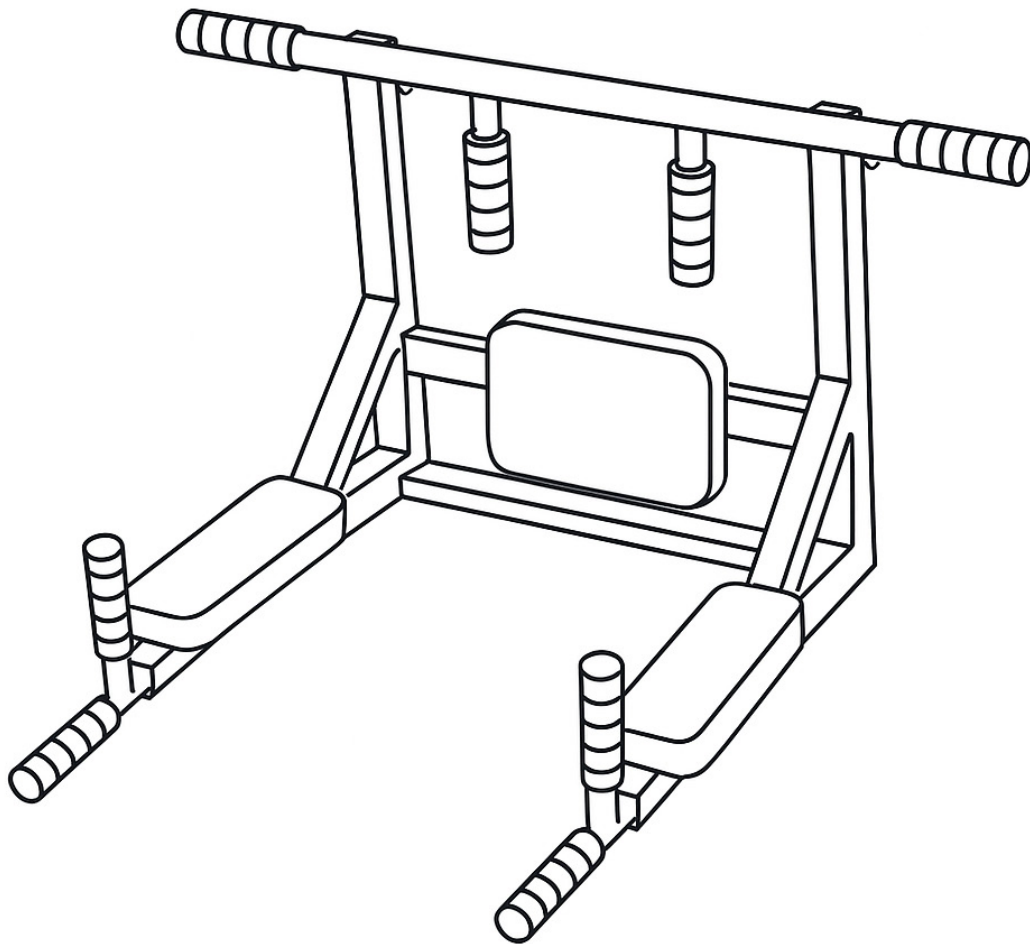

PLEASE READ THESE INSTRUCTIONS CAREFULLY BEFORE USE. RESERVE THE MANUAL FOR FUTURE REFERENCE



Long armrest  
(A)

Square backrest  
(B)



Multifunctional connecting pipe  
(C)



Main connecting pipe  
(D)



Multifunctional connecting pipe and main frame  
(E)



Wall hook

# Backrest and armrest installation

Use screws from group B

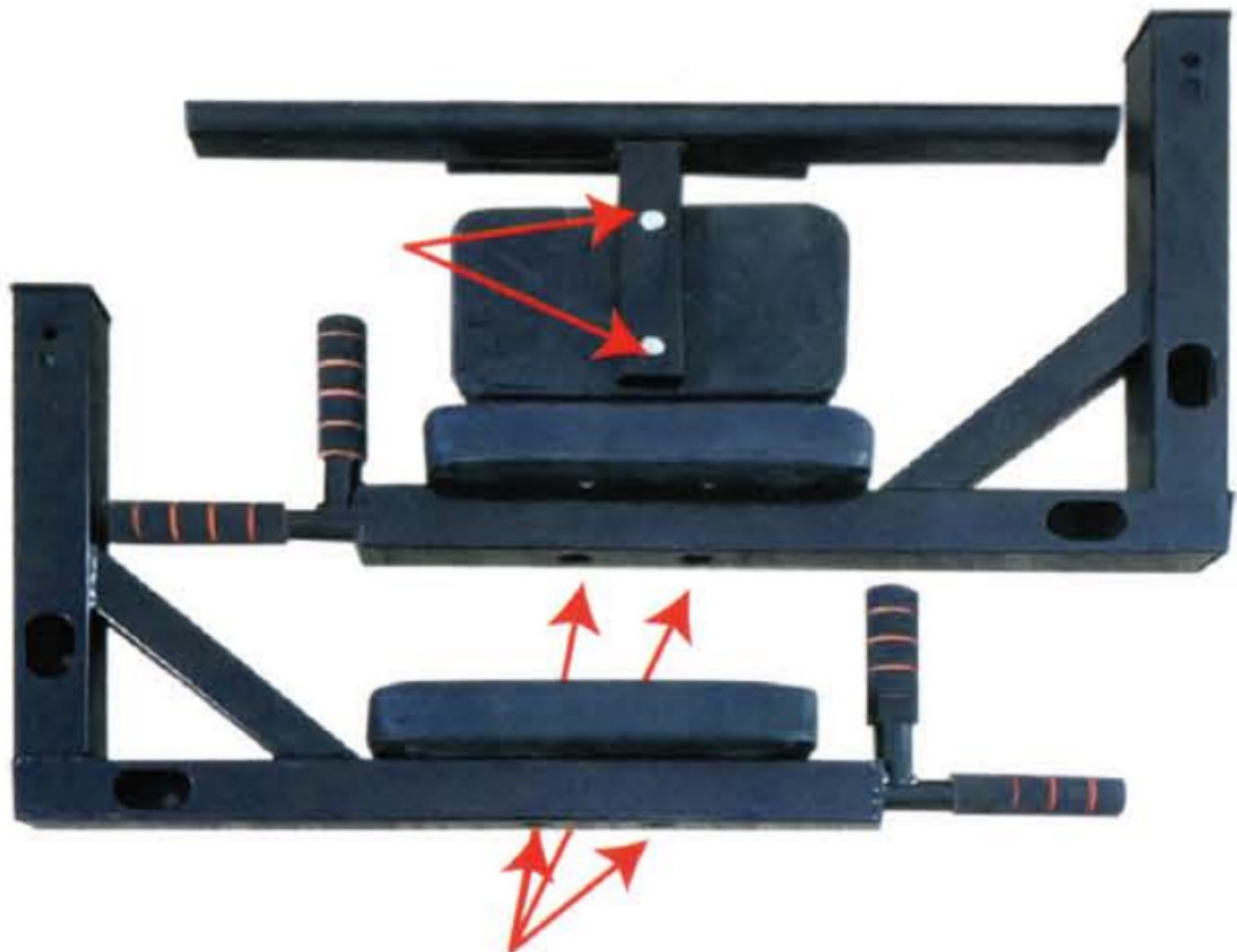

Use screws from group A

# Multifunction connecting tube installation

Use screws from group C



First, join the left and right multifunctional connecting tubes.

Then, place the screws to align them in their holes and adjust them **without fully tightening**.

If you fully tighten them now, it will make the next installation steps difficult to perform correctly.

## Mount the main support



Insert into the corresponding hole, as indicated by the arrows in the figure.

## Fasten the main support

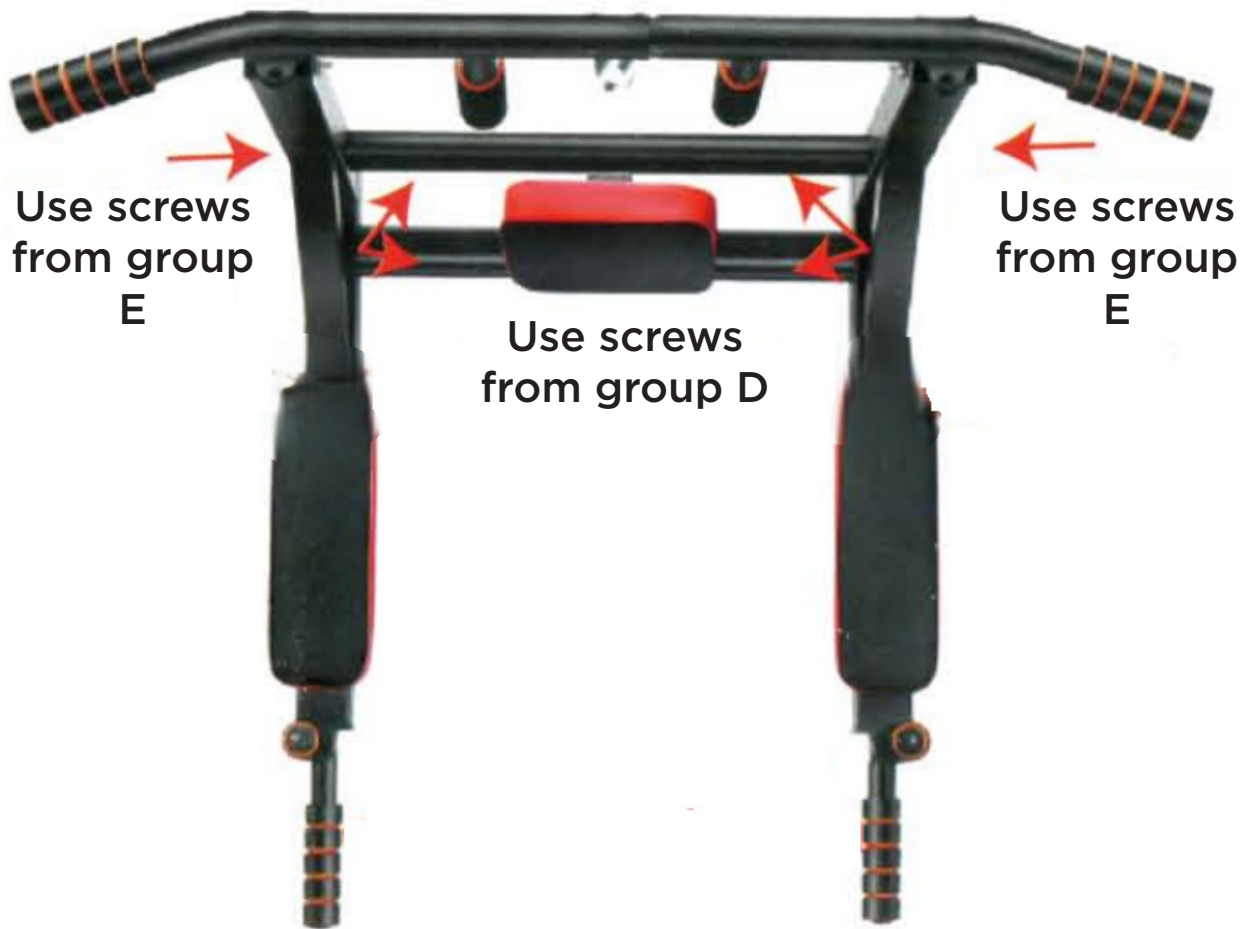

When screwing in the screws, it is recommended that you first loosely insert them into their holes. Once all the screws are in place, you can proceed to tighten them securely. Do this to ensure that the main frame is installed correctly.



Finally, reinforce and tighten all the screws.

The product assembly is complete!

## ¿Necesitás ayuda?

Ingresá a nuestro soporte técnico escaneando el QR o escribinos por nuestros canales oficiales.



**11 6260 1114 (sólo texto)**



**serviciotecnico@bidcom.com.ar**



**www.bidcomservice.com.ar**

**Bidcom**  
SERVICE

