

VETRA

by GADNIC

MANUAL DE USUARIO

INFLADOR DE NEUMÁTICOS INALÁMBRICO
COMPRESOR AUTOS



AV000501

ÍNDICE / CONTENTS / ÍNDICE

ESPAÑOL 03

ENGLISH 05

PORTUGUÊS 07

INSTRUCCIONES DE USO

INSTRUCCIONES DE USO

INFLADOR DE NEUMÁTICOS



LEA ATENTAMENTE LAS INSTRUCCIONES ANTES DE SU USO.
RESERVE EL MANUAL PARA FUTURAS CONSULTAS.

ADVERTENCIA

Los niños no deben operar el inflador de neumáticos solos.

Nunca use el inflador en luz solar directa, altas temperaturas o entornos de alta presión.

Mantenga el inflador alejado del agua y la lluvia; no es apto para su uso en agua.

Para evitar daños, calor excesivo, humos tóxicos, incendios o explosiones, apague el equipo y déjelo enfriar 30 minutos tras 10 minutos de uso.

Apague siempre el interruptor de encendido después de usar.

Antes de usar, lea cuidadosamente todas las advertencias. El uso incorrecto puede causar daños más allá de la responsabilidad del vendedor.

ATENCIÓN

Para minimizar el riesgo de descarga eléctrica, evite exponer el inflador a la lluvia. Se recomienda guardarlo en interiores, lejos de fuentes de fuego.

1. El producto puede experimentar un ligero calentamiento durante el funcionamiento normal, lo cual es habitual.
2. Para prolongar la vida útil, no se recomienda el uso continuo por más de 10 minutos. Si se requiere uso prolongado, realice pausas para enfriar el inflador.

PARÁMETROS DEL PRODUCTO

Modelo de producto	CZK-EB13B
Voltaje	7,4 V
Potencia	60 W

DISEÑO DEL PRODUCTO

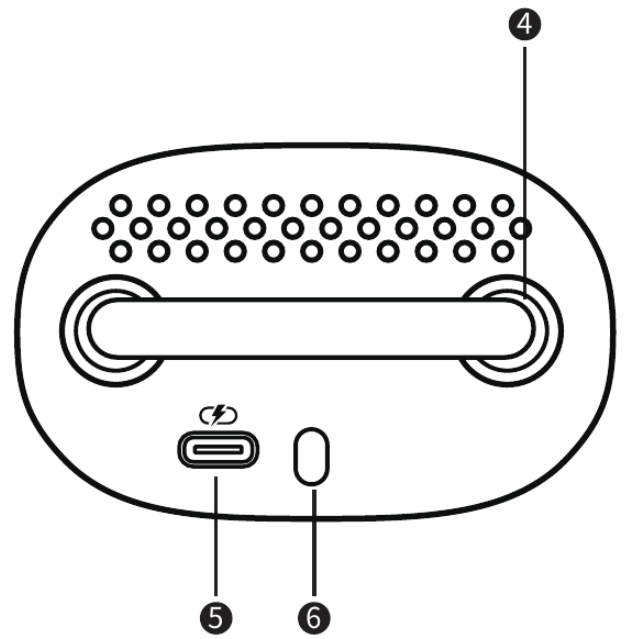
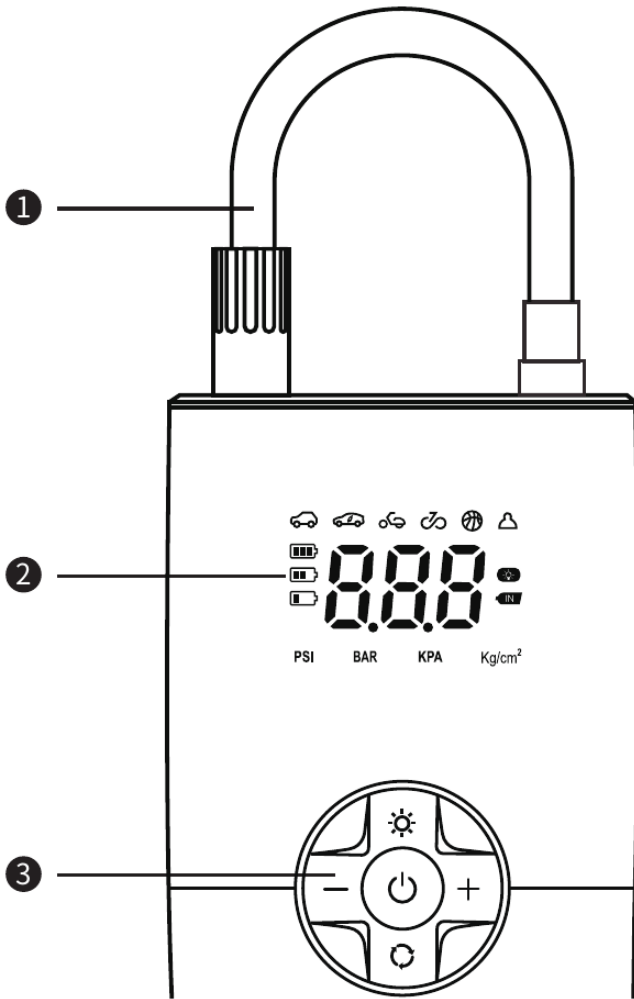

- 1 Manguera de aire
- 2 Pantalla digital
- 4 Puerto de almacenamiento de manguera
- 5 Puerto de carga Tipo-C

- 3 Botones de operación
- 6 Luz

Accesorios: Cable Tipo-C x1 · Boquilla de aire multifuncional

GUÍA DE OPERACIÓN

INSTRUCCIONES DE USO

*Cargue completamente el dispositivo antes de usar.

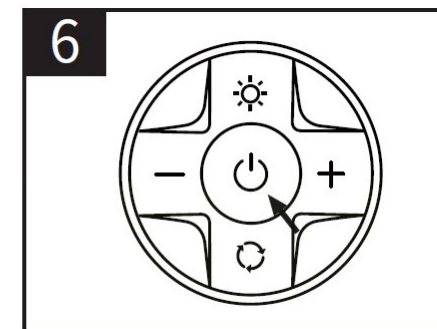
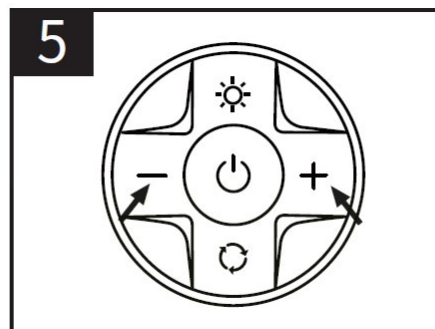
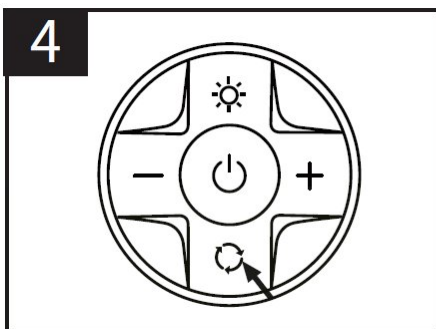
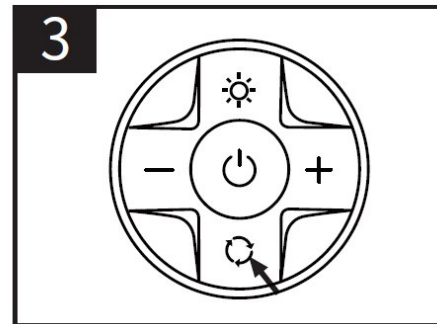
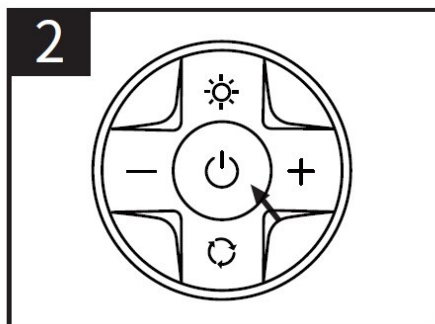
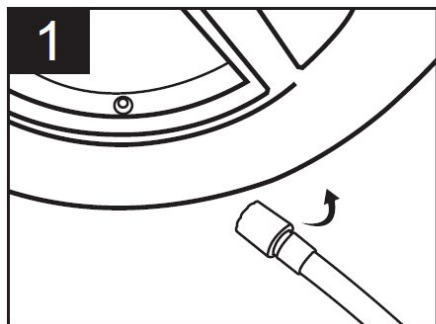

1. Conecte la manguera a la válvula del neumático.

4. Presione  para cambiar entre los 6 modos.

2. Mantenga  presionado para encender.

5. Use + / - para ajustar la presión preestablecida.

3. Mantenga  presionado para cambiar unidad.

6. Presione  para iniciar el inflado.



7. FINALIZADO

El inflador se detiene automáticamente al alcanzar la presión preestablecida.

SEIS MODOS



Automóvil



Vehículo eléctrico



Motocicleta



Bicicleta



Pelotas



Personalizado

PRESIÓN PREESTABLECIDA DEL NEUMÁTICO

Mantenga presionado \mathcal{U} para cambiar la unidad. Use + o - para ajustar el valor numérico y espere unos segundos hasta que los números dejen de parpadear. Active el interruptor de inflado para iniciar. El inflador se detendrá automáticamente al alcanzar la presión especificada.

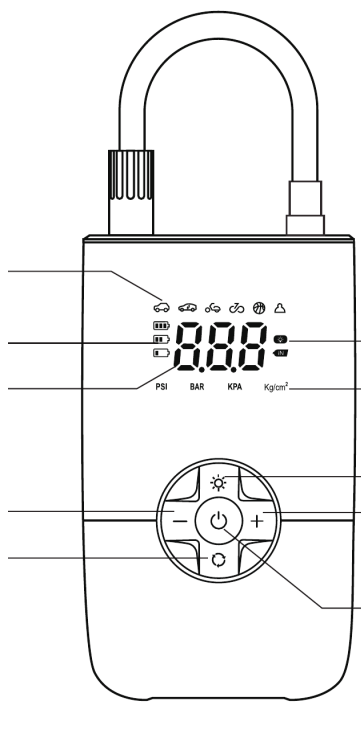

INSTRUCTIONS FOR USE

INSTRUCTIONS FOR USE

TIRE INFLATOR



READ THE INSTRUCTIONS CAREFULLY BEFORE USE.
KEEP THE MANUAL FOR FUTURE REFERENCE.

WARNING

Children must not operate the Tire Inflator alone.

Never use the Tire Inflator in direct sunlight, high temperatures, or high pressure environments.

Keep the Tire Inflator away from water and rain; it is not suitable for use in water.

To avoid damage, excess heat, toxic fumes, fire, or explosion, turn off and allow the Tire Inflator to cool for 30 minutes after 10 minutes of use.

Always turn off the power switch after use.

Before using this product, carefully read all warnings and instructions. Improper use can result in product damage beyond the Seller's responsibility.

ATTENTION

To minimize the risk of electric shock, avoid exposing your Tire Inflator to rain. It is recommended to store it indoors and away from any sources of fire.

1. This product may experience slight heating during normal operation, which is deemed a typical occurrence.

2. In order to prolong the air pump's lifespan, we do not recommend continuous inflation for more than 10 minutes. Should prolonged use be necessary, intermittent breaks are advised to cool down your tire inflator.

PRODUCT PARAMETER

Product model	CZK-EB13B
Voltage	7.4 V
Power	60W

LAYOUT

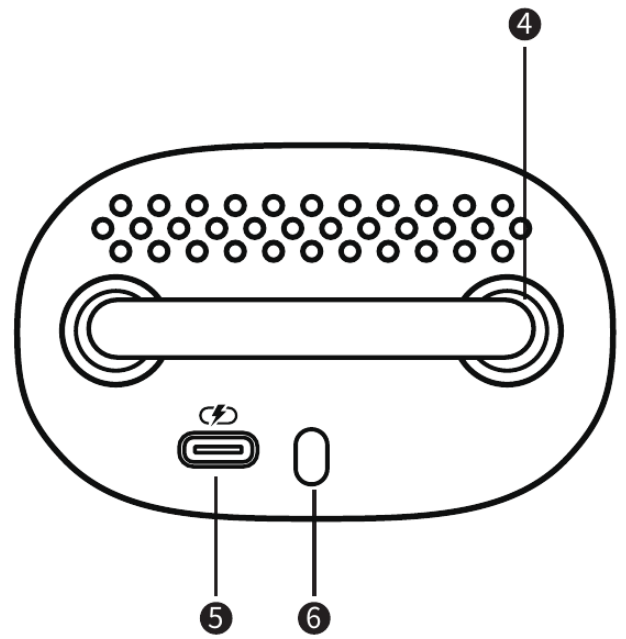
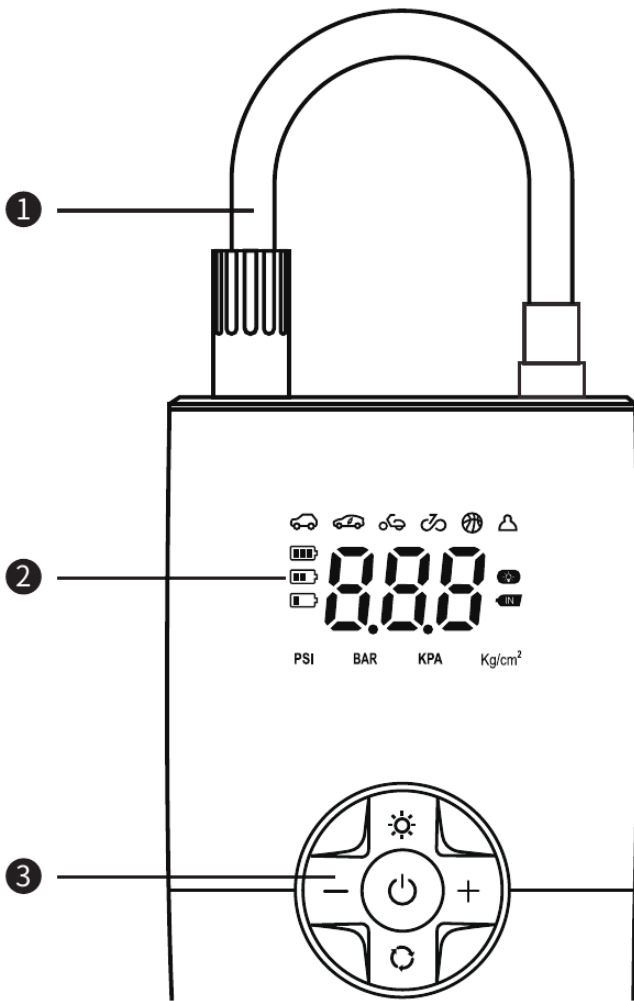

1 Air hose

2 Digital display

3 Operation buttons

4 Air hose storage port

5 Type-C charging port

6 Light

Accessory: Type-C cord x1 · Multifunctional air nozzle

OPERATION GUIDE

INSTRUCTIONS FOR USE

*Please charge it fully before use.

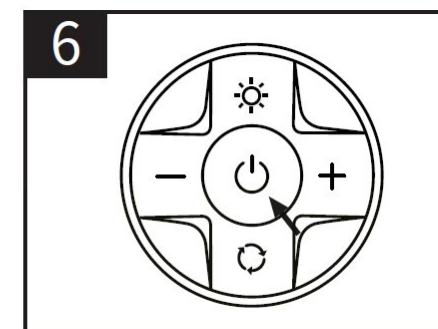
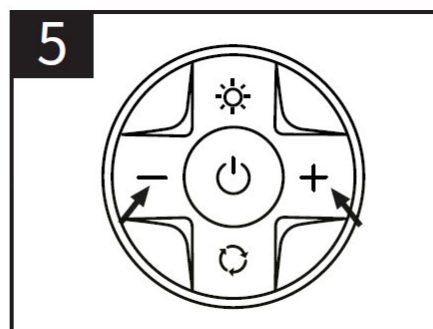
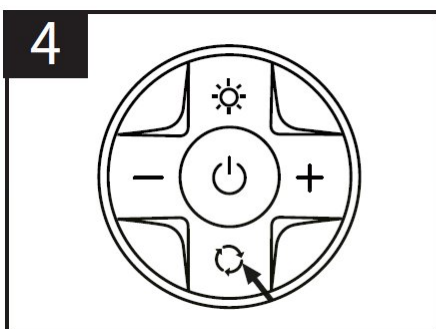
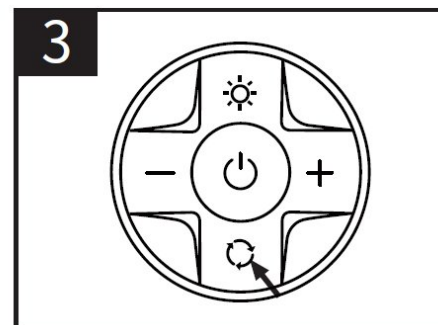
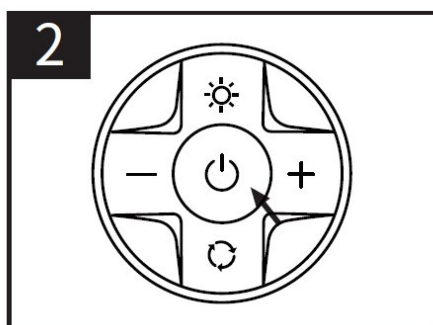
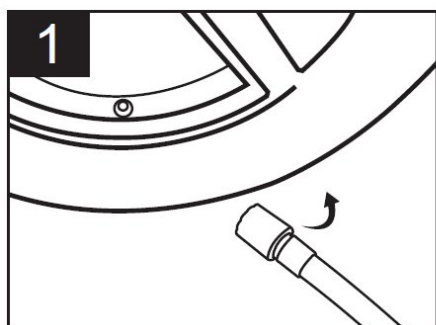

1. Connect the end of the air hose to the tire valve.

4. Press  to switch between six modes.

2. Press and hold  to wake up the tire inflator.

5. Press + / - to preset the tire pressure.

3. Press and hold  to switch the unit.

6. Press  to start the tire inflator.

7

FINISHED

7. FINISHED

The tire inflator will stop automatically once tire pressure reaches the preset value.

SIX MODES



Sedan Car Tire



New Energy Vehicle



Motorcycle



Bicycle



Balls



Custom Mode

PRESET TIRE PRESSURE

Press and hold  to switch the unit. Use the + or - button to adjust the numerical value, and wait a few seconds after setting for the numbers to stop flashing. Then turn on the inflation switch to start the process. The tire inflator will automatically stop inflating when it reaches the specified air pressure.

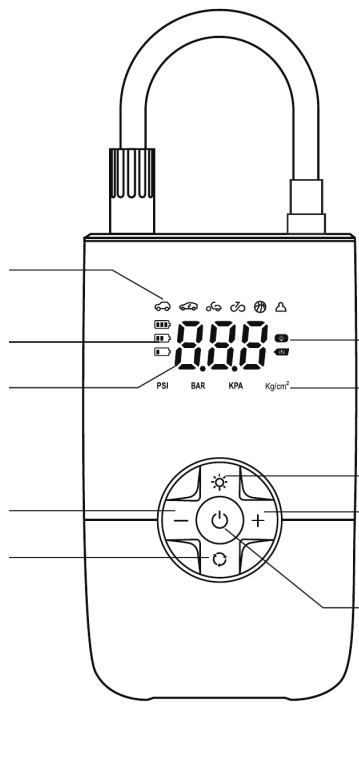

INSTRUÇÕES DE USO

INFLADOR DE PNEUS



LEIA ATENTAMENTE AS INSTRUÇÕES ANTES DE UTILIZAR.
GUARDE O MANUAL PARA CONSULTAS FUTURAS.

AVISO

As crianças não devem operar o inflador de pneus sozinhas.

Nunca use o inflador à luz solar direta, em altas temperaturas ou em ambientes de alta pressão.

Mantenha o inflador afastado da água e da chuva; não é adequado para uso na água.

Para evitar danos, calor excessivo, vapores tóxicos, incêndio ou explosão, desligue o equipamento e deixe-o arrefecer 30 minutos após 10 minutos de uso.

Desligue sempre o interruptor de energia após o uso.

Antes de usar, leia atentamente todos os avisos. O uso incorreto pode resultar em danos além da responsabilidade do vendedor.

ATENÇÃO

Para minimizar o risco de choque elétrico, evite expor o inflador à chuva. Recomenda-se guardá-lo em ambientes fechados e longe de fontes de fogo.

1. Este produto pode apresentar um ligeiro aquecimento durante o funcionamento normal, o que é considerado normal.
2. Para prolongar a vida útil da bomba, não recomendamos o uso contínuo por mais de 10 minutos. Se necessário, faça pausas intermitentes para arrefecer o inflador.

PARÂMETROS DO PRODUTO

Modelo do produto	CZK-EB13B
Tensão	7,4 V
Potência	60 W

LAYOUT DO PRODUTO

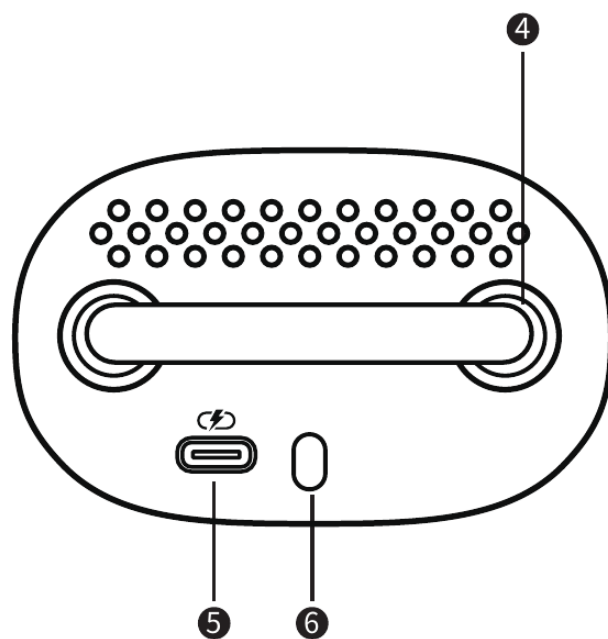
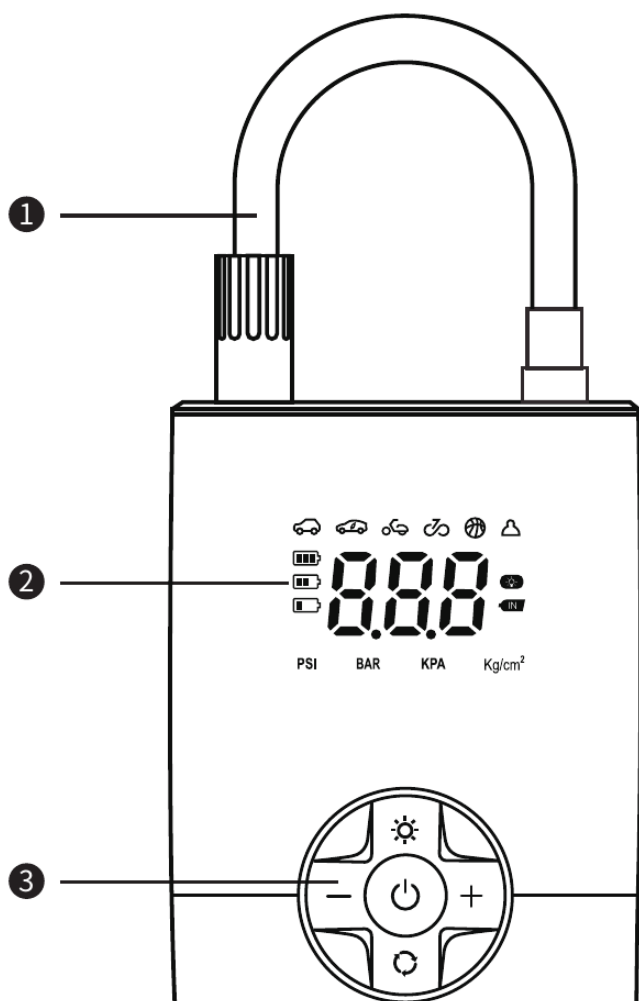

- 1 Mangueira de ar
- 2 Visor digital
- 3 Botões de operação
- 4 Porto de armazenamento da mangueira
- 5 Porto de carregamento Tipo-C
- 6 Luz

Acessórios: Cabo Tipo-C x1 · Bico de ar multifuncional

GUIA DE OPERAÇÃO

INSTRUÇÕES DE USO

*Por favor, carregue completamente antes de usar.

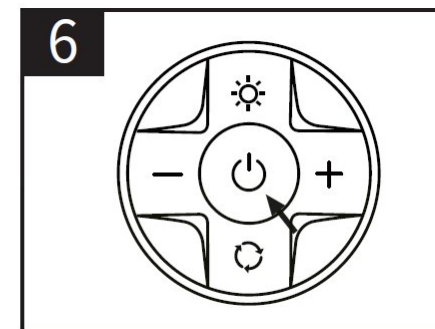
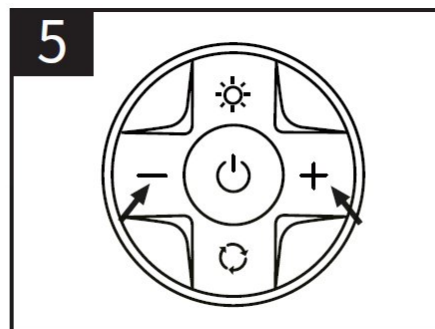
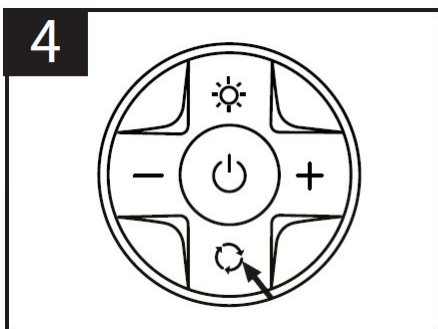
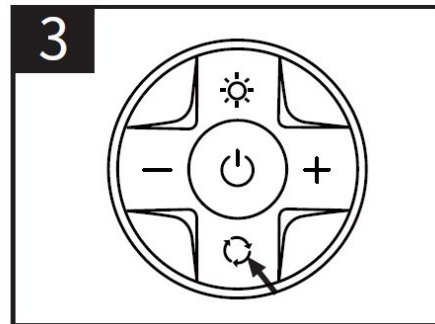
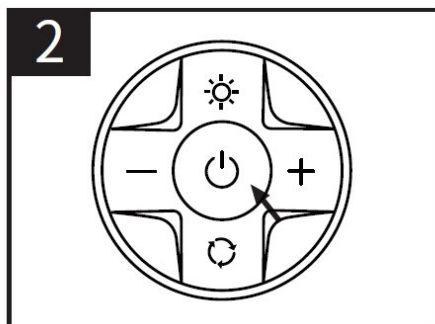
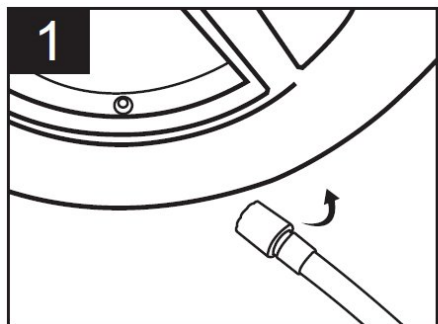

1. Conecte a mangueira à válvula do pneu.

4. Pressione  para alternar entre os seis modos.

2. Mantenha  pressionado para ligar o inflador.

5. Use + / - para ajustar a pressão predefinida.

3. Mantenha  pressionado para trocar a unidade.

6. Pressione  para iniciar o inflador.

7

FINISHED

7. CONCLUÍDO

O inflador para automaticamente quando a pressão do pneu atinge o valor predefinido.

SEIS MODOS



Automóvel



Veículo elétrico



Motocicleta



Bicicleta



Bolas



Personalizado

PRESSÃO PREDEFINIDA DO PNEU

Mantenha pressionado  para trocar a unidade. Use + ou - para ajustar o valor numérico e aguarde alguns segundos até os números pararem de piscar. Ligue o interruptor de inflagem para iniciar. O inflador parará automaticamente ao atingir a pressão especificada.

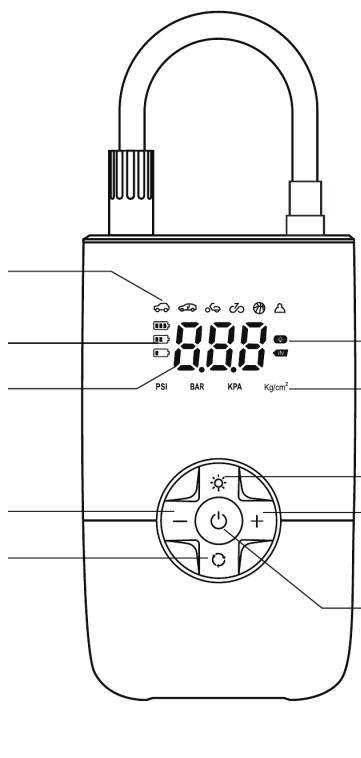

¿Necesitás ayuda?

Ingresá a nuestro soporte técnico escaneando el QR o escribinos por nuestros canales oficiales.



11 6260 1114 (sólo texto)



serviciotecnico@bidcom.com.ar



www.bidcomservice.com.ar

Bidcom
SERVICE

